

tapflo®

AIR OPERATED DIAPHRAGM PUMPS

edition 2017 rev 2

Featuring
NEW TC series
Intelligent pumps



» All about your flow

www.tapflo.com

All about your flow

Tapflo is a leading pump manufacturer with the ambition to provide a wide range of premium products for various industrial applications. We focus on delivering the best fluid processing solutions and support on all stages of the process, worldwide.



About Tapflo

Tapflo is an independent, Swedish, family owned, manufacturer and global supplier of air operated diaphragm pumps, centrifugal pumps and other industrial process equipment. The company was founded in Kungälv, Sweden in 1980 and has since then been working with design and manufacture of thermoplastic, metal and sanitary series diaphragm pumps and also with complete range of centrifugal pumps and industrial equipment. After years of dynamic development the company evolved into Tapflo Group with worldwide operations. Tapflo Group is represented by own companies and independent distributors all over the world on 6 continents.

Quality certified

At Tapflo we believe that quality is one of the highest values, both for our customers as well as our employees. As a result, we comply with various globally recognised certification and quality control institutions. Many of our products comply with EC ATEX directives for equipment intended for use in explosion hazardous environments.

The aseptic series is EHEDG certified (European Hygienic Engineering & Design Group), the pharmaceutical series has USP VI and EC 1935/2004 approval.

All our products are obviously CE marked and followed by our comprehensive instruction manuals. Tapflo manufacturing process is certified according to ISO 9001:2015.



Our values

■ Long term engagement is our core

Our aim is to continuously provide premium products according to evolving needs of our customers. That is why we see each customer relationship as a long term commitment.

■ Local means on your terms

Tapflo is your global partner providing local support. No matter where your plant is located you can expect us to support you locally.

■ Flexibility the foundation of good service

We are prepared to deal with reality, knowing that in practice this means answering questions, offering solutions and supplying spare parts with a minimal loss of time.

■ Customizing to bring the product to the needs

Our intention is always to help our clients find the most cost effective solutions to increase their company's efficiency. If this means changing the design of the pump we see it as a challenge - not a problem.

■ To produce is to develop

Being actively involved in the manufacturing of a product, it is almost impossible not to discover ways to improve it. This allows us to frequently offer solutions that are even more sustainable and efficient.

Diaphragm pumps

most versatile pumps on the market

■ Working principle

Tapflo diaphragm pump is driven by compressed air. Two diaphragms are working simultaneously to prime and push the liquid through the pump system. Valve balls work as check valves to let the liquid through in the right direction.

During each cycle the air pressure on the back of the discharging diaphragm is equal to the head pressure on the liquid side. Tapflo diaphragm pumps can therefore be operated against a closed discharge valve with no adverse effect to the life of the diaphragms.

Suction

One diaphragm creates a suction action when being pulled back from the housing.

DISCHARGE

OPEN

DIAPHRAGM
STROKE

AIR

CLOSED

SUCTION

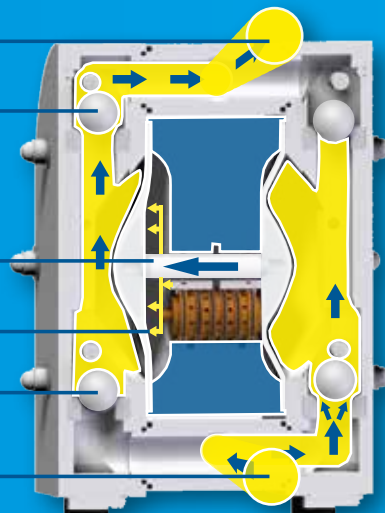

Discharge

The other diaphragm simultaneously transmits the air pressure to the liquid in the housing, pushing it towards the discharge port.

■ Fast facts

Capacity

0-820 l/min

0 - 216 US gal/min

Pressure

0 - 8 bar (max 16 bar for TF series)

0 - 116 PSI (max 232 PSI for TF series)

Connection sizes

1/4" up to 3" (DN8 - DN80)

Pump materials

PE, PTFE, aluminium, cast iron, stainless steel AISI 316L, and PTFE coated aluminium

■ Features & Benefits

✓ Run dry without damage
Easy to use, no need of guarding device

✓ Infinitely variable flow control
Flexible and easy to adjust

✓ Self-priming up to 5 m from dry suction pipe
More options of installation

✓ No electricity needed
Explosion proof versions
Ex-zone 1 available
(ATEX group II, cat 2)

✓ Few components
Low down time and maintenance costs

✓ Solid, strong and long life design
Low maintenance costs

✓ Lubrication free air distribution system
Saves the environment from pollution

✓ Air operated
Can run against a closed pipe or closed valve without damage. Easy to install without special training (no electricity)

How to install Tapflo pumps

The Tapflo pumps are flexible in their ease of installation. The in- and outlet ports are rotatable more than 180° to fit your piping system (PE & PTFE and metal series pumps).

Flooded

The piping system is designed with a positive suction head. This is the best way of installation where it is necessary to completely evacuate all liquid from the container, or where viscous (thick) products are transferred.

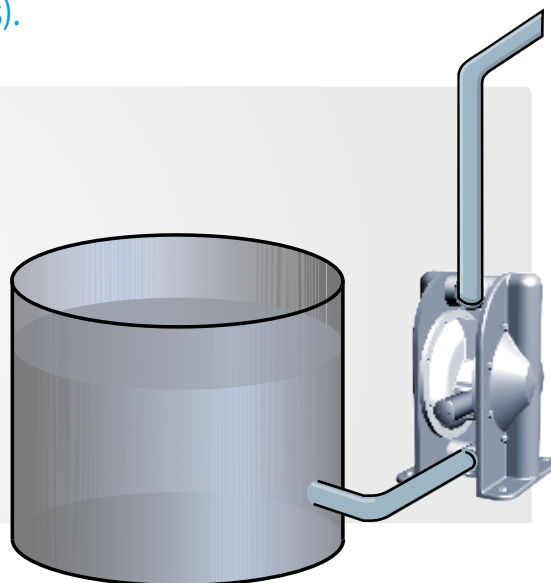

Self-priming

The Tapflo pump is designed to pull a high vacuum. It is able to evacuate an empty suction pipe without any damage to the pump. The suction lift is up to 5 meter (16.4') from an empty suction pipe and up to 8 meter (26.2') from a wetted pipe. The suction capability depends on the pump size (see pages 16, 23, 28).

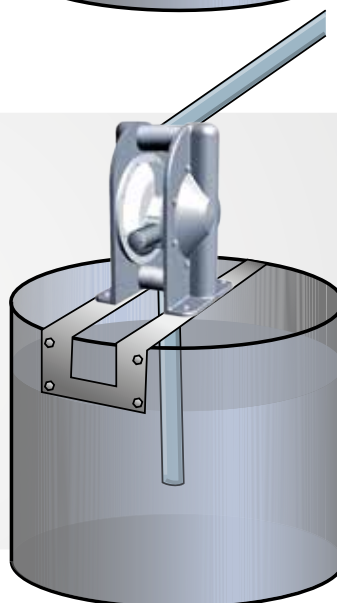

Submerged

All Tapflo pumps may be submerged into the liquid. It is important to make sure that all components which are in contact with the liquid are chemically compatible. The air exhaust must be led to the atmosphere by means of a hose.

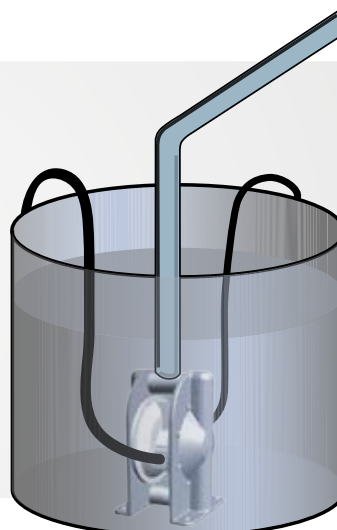

Key components of the Tapflo pump

Three major components are especially vital for the function of the pump...



Long life diaphragms

Tapflo diaphragms are of composite construction, superior for continuous heavy duty service, with a completely smooth surface in contact with the liquid. This results in no leak through and a diaphragm which is easy to keep clean.

The diaphragms are available in various materials and colours to suit any requirements, they are made from **EPDM, NBR, FKM, PTFE, PTFE TFM 1705b, EPDM white, PTFE with white EPDM back, NBR white.**



■ Multilayer Design

An advanced process of performing, curing, trimming and finishing result in a long life composite diaphragm that will last for many millions of stroke cycles. All compounds are specially developed and optimized for composite diaphragm technology and compression molding production. Components are chemically bonded by bonding agents and adhesives.

- (1) PTFE TFM layer | (2) Elastomer upper half | (3) Core (metal)
- (4) Fabric | (5) Elastomer lower half

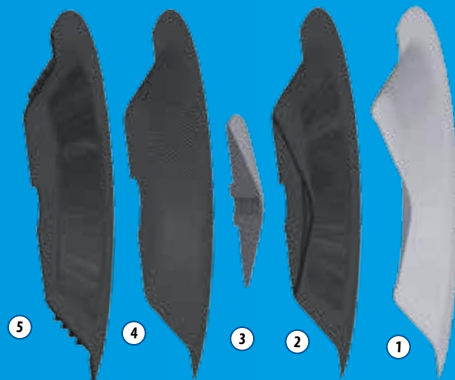

Energy saving drive

The air valve is the driving heart of the pump, distributing the compressed air to the chambers behind the diaphragms. The air valve is placed in the middle of the pump between the diaphragms, to achieve short air ways and a minimum of so called dead volumes. This all together is the key to a reliable and energy saving drive.

It is made for maintenance free duty with no lube air, thanks to the ingenious sealing system. **It will not only save your money for lubrication, it will also protect environment from pollution.**

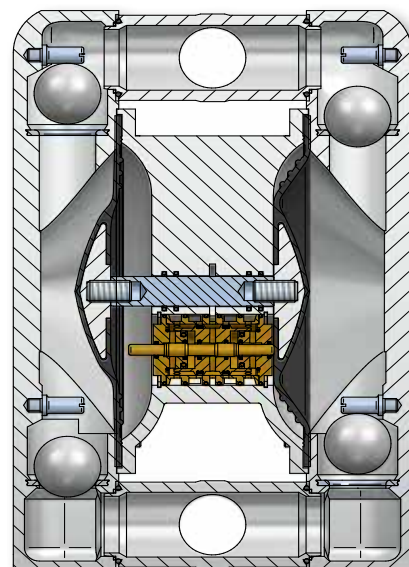

The valve body is made from **brass** or optional **PET** or **stainless steel AISI 316**.



Ball check valves

The Tapflo pump is fitted with four check valves, making sure that the liquid is transferred in the right direction through the pump.

The ball type valve is the most simple and reliable valve design. It has a good sealing capability and is easy to keep clean and to replace if necessary.

The ball valve materials are available in **EPDM, NBR, PTFE, PTFE TFM 1635, PE1000, FKM, PU, Ceramic, SiC, AISI 316L** to suit any kind of liquid.



Flap valves (Sanitary pumps)

Flap valves are used when pumping liquids containing big solids without damage. We are able to pump solids up to **18 mm** in **T80** and **T125**, **44 mm** in **T225** and **T425** and **100 mm** in **T825**. Pumps can reach dry suction lift of 4,5 meters.

Tapflo flap valves are durable, have only two spare parts and are hygienic thus easier to clean.



Magnetic ball lifters (Sanitary & EHEDG pumps)

Possibility to drain the content of the pump is crucial in most hygienic applications. [Ball lifting system from Tapflo could not have been easier.](#)

Magnetic ball lifters are implemented in Sanitary and Aseptic EHEDG series AODD pumps, to enable pump emptying without removing it from the installation when no other draining option is available. Rotating the pump is no longer needed.



Valve ball

Magnet lifter

Manifold



■ Working principle

Valve ball, either made of AISI 420 or PTFE with steel core, is lifted by magnet lifter attached onto the manifolds.



Applications. Where do you use Tapflo pumps?

Tapflo pumps are some of the most versatile pumps on the market today. They can be used in a variety of installations in numerous applications. Thanks to the simple operating principle, with a compact and reliable design, Tapflo diaphragm pumps meet the demands of heavy industrial duties.

Various liquids - Tapflo pumps are compatible with a very wide range of chemicals:

- » Corrosive and chemical aggressive
- » High and low viscous
- » Abrasive
- » Solid content
- » Shear sensitive
- » Flammable



Chemical industry

Transfer of all kind of acids, alkalis, alcohol, solvents and shear sensitive products such as latex and emulsions, as well as chemical waste products.

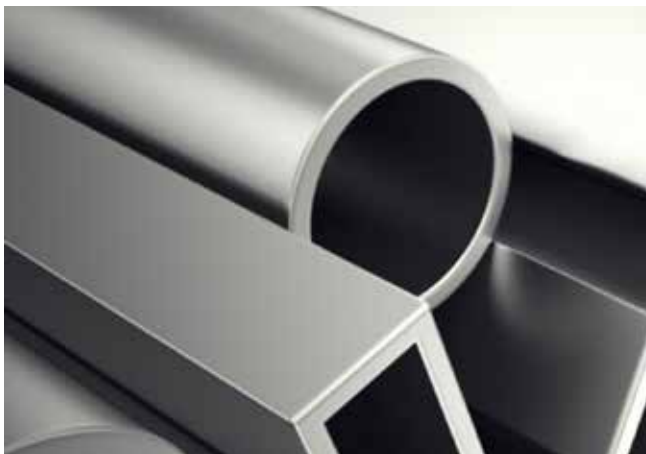

Surface conditioning

Transport of chemicals from storage tanks, containers and baths, for example in pickling, galvanization and degreasing. Handling of waste products.



Water treatment

Pumping samples, dosing acids and alkalis for pH-control. Transfer of flocculent, suspensions, chemical reagents and sludges. The pumps are resistant to hydrochloric acid and ferric chlorite, plus many others.



Pulp and paper industry

Transport of glue, sodium silicate, colour and titanium oxide etc.
Bleaching products, sampling and waste water handling.



Hygienic applications

Transfer of food products like soup, cream, syrup, milk, yoghurt, flavours, spirit, chocolate, dough, creams, paste, perfumes and toothpaste. Service applications as spraying of cleaning liquid in CIP systems.



Mechanical industry

Handling of oil, fats, lubricants, cooling liquids, washing and cleaning liquids, solvents and waste products etc.



Paint, print and varnish industry

Transfer of water- and solvent based paints, ink, varnish, glue, adhesives and solvents. Transfer, recirculation and blending of ink in printing industries.

PE & PTFE series pumps

Tapflo pumps made from polyethylene (PE) or PTFE are suitable for handling almost any kind of liquid whether it is viscous, chemically aggressive or with solids.



Polyethylene pumps

Polyethylene (PE HD) has a superior wear resistance which is 6 – 7 times better than for polypropylene (PP). This fact makes the pump suitable for handling abrasive slurries etc. PE is resistant to most kind of aggressive chemicals such as concentrated acids and alkalis. Maximum liquid temperature is 70°C. Tapflo uses different grades of PE depending on the part. For valve seats and ball stoppers, which are most vulnerable to wear - UHMW PE1000 is used for best mechanical strength and abrasion resistance.

PTFE pumps

PTFE (virgin polytetrafluorethylene) is a thermoplastic polymer with superior chemical resistance. The PTFE pump will handle even the most aggressive acids, for instance concentrated nitric acid. Maximum liquid temperature is up to 100°C.



EN 10204



AT 



The PE & PTFE pump range

- » TR9 - 11 l/min, 1/4"
- » TR20 - 24 l/min, 3/8"
- » T50 - 60 l/min, 1/2"
- » T100 - 125 l/min, 1"
- » T200 - 330 l/min, 1 1/2"
- » T400 - 570 l/min, 2"
- » T800 - 820 l/min, 3"

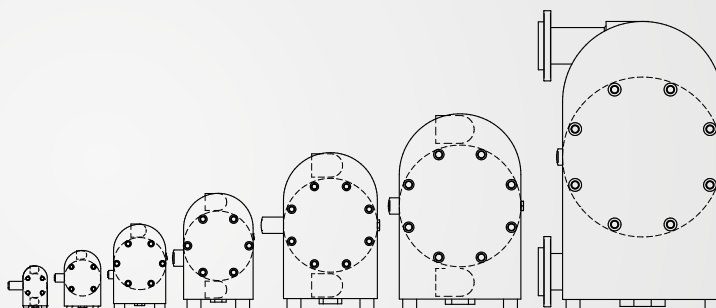

Typical applications

Industry	Example of applications
» Chemistry	Acids, alkalis, alcohol, solvents, latex, emulsions
» Food	CIP fluid, flavoring, pigments
» Pulp & Paper	Glue, slurries, adhesives, dispersions, resins, sodium silicate, titanium oxide
» Surface conditioning	Electroplating baths, various acids, solvents, anodic sludge, varnish, enamels
» Water treatment	Sludge handling, filter press applications, neutralization and flocculants
» Electronics	Carrier fluids, ultra-pure liquids, electroplating solutions, mercury, solvents
» Print & paint	Glue, additives, varnish, ink, paint, latex, acid, resins, pigments

The ingenious Tapflo design

Few components and a simple but ingenious design is peculiar for all Tapflo pumps. It is a compact pump, easy and quick to maintain, keeping your service costs and process down time to a minimum.

Flexible installations

The connections may be rotated 180°. Simply turn the connections to fit your piping system. Threaded BSP or NPT plastic connections is standard, AISI 316 or other connections types are also available.

Solid and strong

The pump body is machined from solid PE or PTFE. The solid design will stand against mechanical forces as well as aggressive chemicals.



Low air consumption

The air distribution system is designed with shortest possible air distribution ways. This eliminates "dead spaces", resulting in high efficiency and low air consumption.

Chemical design

The compound diaphragm has a completely smooth liquid side surface and with no metal in contact with the liquid. Ideal for a safe chemical handling.



PE pumps - suitable for most chemicals and abrasive medias



PTFE pumps - suitable for the most aggressive chemicals

Special versions



Drum pumps | TD series

It is fitted with a drum tube in polypropylene (PP) or PTFE and a handle in stainless steel AISI 316L.



The drum tube is delivered in any length up to 2 m.

Handle your liquids comfortable. You will easily move your Tapflo drum pump between drums and containers.

The PE & PTFE drum pumps range

- » TRD20 - 24 l/min, 1/2" suction, 3/8" discharge
- » TD50 - 60 l/min, 1" suction, 1/2" discharge
- » TD100 - 125 l/min, 1" suction and discharge

■ Features & Benefits

-  **No rotating parts**
 Gentle liquid handling – ideal for shear sensitive liquids or abrasive products.
 Adjustable suction pipe length.
-  **High pressure**
 Able to handle even high viscous products
-  **Infinitely variable flow**
 Easy to adjust the flow for a safe fluid handling



Integrated flanges | 3D/3A

Pumps with integrated flanges are a robust and solid design. When there is a risk of transferring of vibration from the installation to the pump, the solid manifolds provide better stability and sealing for the pump.

More material and robust construction is a perfect solution for most demanding applications such as in TF Filter press pumps where pump operates at higher pressures.

- » **Available for sizes:** T50, T100, T200, T400
- » **Available materials:** PE, PE cond., PTFE, PTFE cond.
- » **Flange standard 3A** = ANSI flanges **3D** = DIN flanges

Special versions



AT

Explosion proof pumps | TX series

The ATEX directive 2014/34/EC (also known as ATEX 114) is applicable on products used in explosion hazardous zones.

Tapflo pumps made from conductive (carbon filled) plastics PE or PTFE are made for use in explosion hazardous environments. They can be used in Ex-zone 1. The conductive material ensures that no electrostatic loads will be accumulated in the pump. The conductive pigments in the material reduces the surface resistance. Transfer of alcohol and solvents are examples of applications for the Tapflo TX pumps.

Pumps certified according to 2014/34/EC (ATEX)

Group:	II
Category:	2G/2D
Apparatus group:	IIB
Temperature class:	T4



Twin pumps | TT series

Tapflo PE & PTFE series pumps may be fitted with double in/outlet to achieve "two pumps in one" for blending, mixing or recirculation of liquids.

The liquid in one pump chamber is separated from the other one.

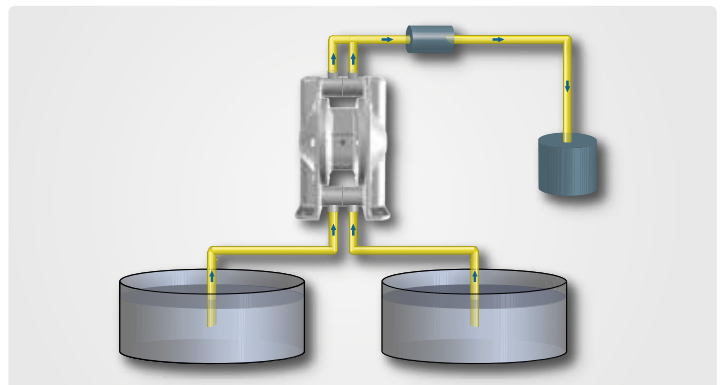

Example of applications

- » Mixing of two liquids with one pump (50/50 ratio) (installation example above)
- » Transfer and return of printing ink from storage to ink tray
- » Transfer and agitation of liquids with one pump

Metal series pumps

The compact, smooth and simple design is common for this series. Materials available are aluminium, cast iron, stainless steel and PTFE coated aluminium.



Aluminium and cast iron pumps

For transfer of pH-neutral fluids, both thin, thick, high solid content or abrasive. The aluminium and cast iron pumps are found in most fields; workshop and paint industries, purifying plants etc., to mention only a few.

AISI 316 stainless steel pumps

Made in lost wax cast method, ensuring great accuracy and finish. The stainless steel pumps combine great mechanical strength with good chemical features. AISI 316 is resistant to aggressive liquids like nitric acid and sodium hydroxide. The centre block, which is not in contact with liquid, is made from corrosive resistant polypropylene (PP) as standard (other materials upon request).



The metal pump range

- » T25* - 26 l/min, 1/2"
- » T70 - 78 l/min, 3/4"
- » T120 - 158 l/min, 1"
- » T220 - 330 l/min, 1 1/2"
- » T420 - 570 l/min, 2"
- » T820 - 820 l/min, 3"

* = aluminium and cast iron only

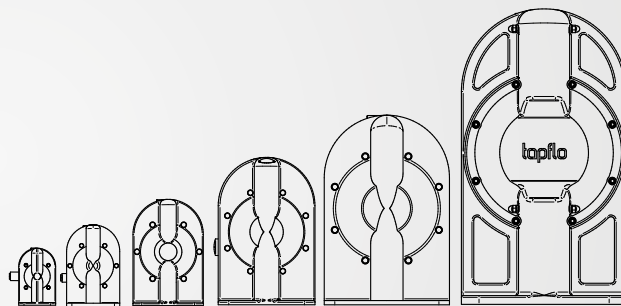

Typical applications

Industry	Example of applications
» Workshop	Oil, fat, solvents, water, cooling fluid, lubricants
» Print & paint	Glue, additives, varnish, ink, paint, latex, acid, resins, pigments
» Mining & construction	Adhesives, sump, dewatering, coal sludge, pastes
» Ceramic industry	Abrasives, glaze, water, enamels, clay
» Chemistry	Acids, alkalis, alcohol, solvents, latex, emulsions

The ingenious Tapflo design

You will discover the ingenious simplicity when you maintain the pump.
We use approximately **70% fewer parts compared with other brands.**



Optional Camlock connections

Metal series diaphragm pumps can be ordered with CAMLOCK connections. The coupling is connected by simply opening the coupler arms and inserting the adaptor into the coupler.

Durable valve seats

The valve seat is under constant stress from the movement of the valve ball. To obtain the best wear resistance, the integrated seat is made from AISI 316 stainless steel.

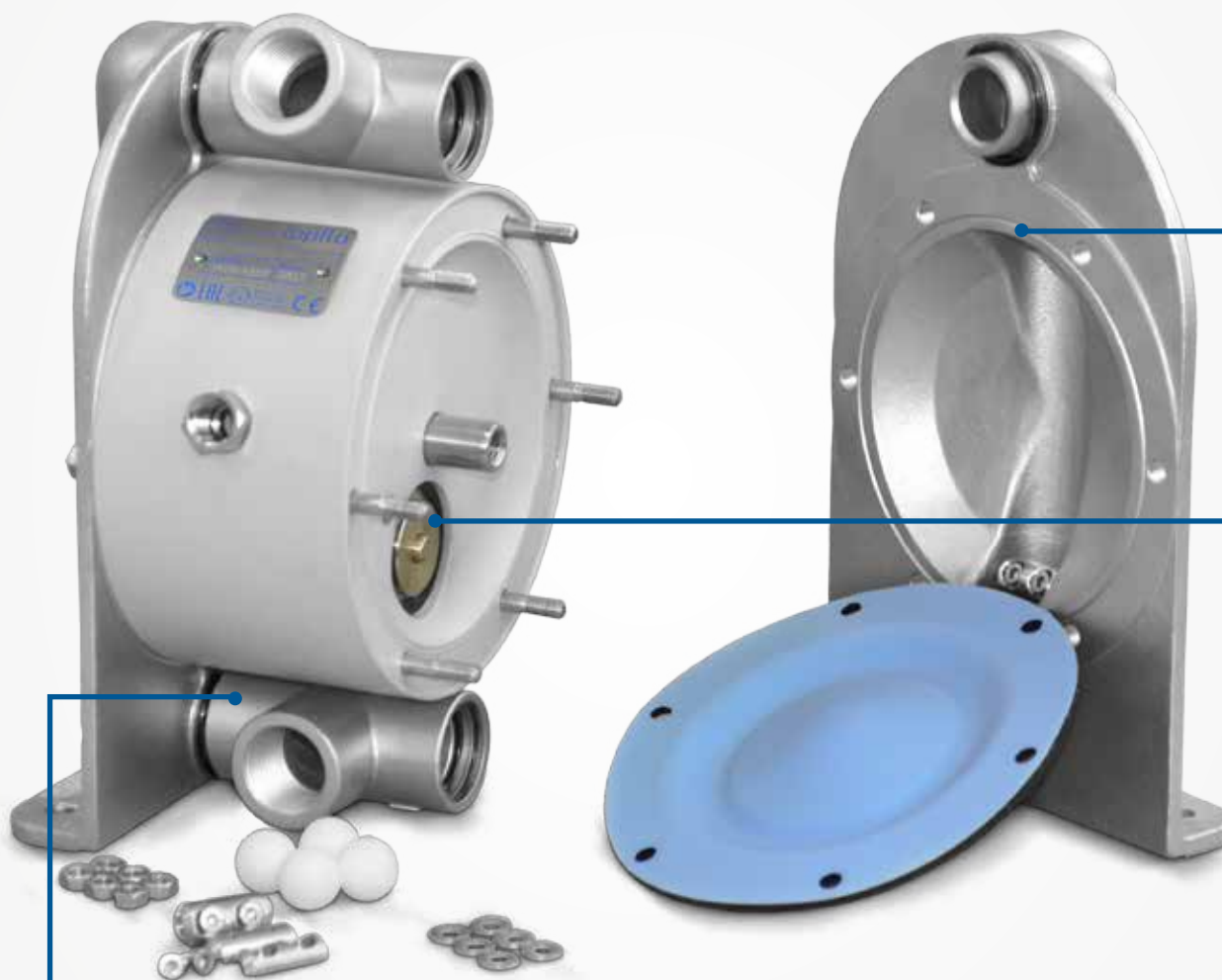

Flexible installations

The connections may be rotated 180°. Simply turn the connections to fit your piping system. Threaded BSP or NPT connections is standard. Twin connections are also available.

Low air consumption

The air distribution system is designed with shortest possible air distribution ways. This eliminates "dead spaces", resulting in high efficiency and low air consumption.



Aluminium and cast iron - suitable for thick and thin pH neutral liquids



Stainless steel - suitable for chemicals

Special versions



Drum pumps | TD series

The Tapflo drum pump is ideal for mobile use and is available in aluminium or stainless steel AISI 316 SS. It is fit with an ergonomic designed handle in stainless steel AISI 316. The drum tube is delivered in any length up to 2 m. The Tapflo diaphragm drum pump has many advantages compared with conventional drum pumps as stated below.

Handle your liquids comfortable. You will easily move your Tapflo drum pump between drums and containers.

The Metal drum pumps range

- » TXD25 - 25 l/min, 1/2" suction and discharge
- » TXD70A - 70 l/min, M30 x 1,5 suction; 3/4" discharge
- » TXD70 S - 70 l/min, 3/4" suction and discharge
- » TXD120A - 120 l/min, M30 x 1,5 suction; 1" discharge
- » TXD120S - 120 l/min, 1" suction and discharge

■ Features & Benefits

- ✓ **No rotating parts**
 Gentle liquid handling – ideal for shear sensitive liquids or abrasive products.
- ✓ **High pressure**
 Able to handle even high viscous products
- ✓ **Infinitely variable flow**
 Easy to adjust the flow for a safe fluid handling



Ball lifters TL

This option is a great way to empty the pump of liquid if there is no possibility of pump disconnection from the installation.

With this easy solution you can simply raise the ball from the valve seat and allow the liquid to flow out of the pump.

» Available for sizes: T70 | T120 | T220 | T420

Special versions



AT

Explosion proof pumps | TX series

The ATEX directive 2014/34/EC (also known as ATEX 114) is applicable on products used in explosion hazardous zones. All aluminum and cast iron pumps are by standard ATEX approved, having model names TX... The standard stainless steel pumps are not allowed to operate in environments. special conductive TX pumps are available for such applications. All plastic parts utilized in such pumps are made from conductive (carbon filled) materials thus made for use in explosion hazardous environments. What is more ATEX pump are equipped with a grounding connection.

They can be used in Ex-zone 1. The conductive material ensures that no electrostatic loads will be accumulated in the pump.

Pumps certified according to 2014/34/EC (ATEX)

Group:	II
Category:	2G/2D
Apparatus group:	IIB
Temperature class:	T4



Twin pumps | TT series

Tapflo metal series pumps may be equipped with double in/outlet to achieve "two pumps in one" for blending, mixing or circulation of liquids. The liquid in one pump chamber is separated from the other one.

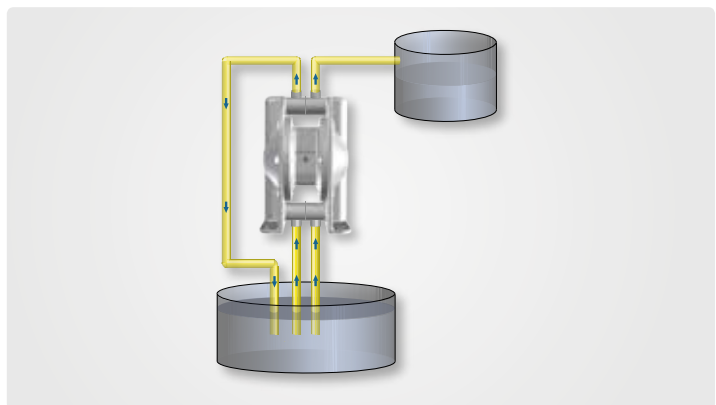

Example of applications

- » Transfer of two different liquids, two pumps in one
- » Mixing of two liquids with one pump (50/50 ratio)
- » Transfer and return of printing ink from storage to ink tray
- » Transfer and agitation of liquids with one pump (installation example above)

Sanitary series pumps

Hygienic design - made from electropolished stainless steel AISI 316L to meet the requirements in hygienic installations.



The Tapflo sanitary series is particularly designed to meet the requirements of the food, beverage, pharmaceutical and cosmetic industries.

Lubrication free air distribution system, maintenance free ball check valve system and total visual inspection of the wetted parts are some of the major features for this pump series.

The materials used on certain models comply with the FDA guidelines.

Models with extra fine surface finish $Ra < 0.8$ and $Ra < 0.5$ are available upon request.



EN 10204



The sanitary pump range

- » T30 - 28 l/min, 1"
- » T80 - 78 l/min, 1"
- » T125 - 155 l/min, 1 1/2"
- » T225 - 330 l/min, 2"
- » T425 - 570 l/min, 2 1/2"
- » T825 - 820 l/min, 3"

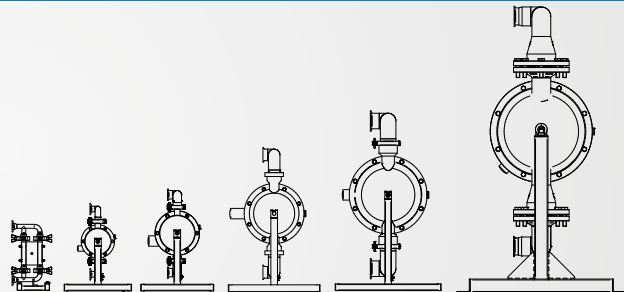

Typical applications

Sector	Example of applications
» Dairy products	Milk, cream, yogurt, cream cheese, melted cheese
» Grocery	Ketchup, mayonnaise, tomato products, mustard
» Beverages	Flavors, coloring, fruit juice
» Bakery	Dough, ingredients
» Brewery	Beer, flavors, coloring, wort
» Hygiene	Soap, shampoo
» Cosmetics	Cream, alcohol, perfume

The sanitary design

Made to be clean

Quick dismantling

The clamp system ensures rapid dismantling without any tools.

Pollution free air valve

The sealing system is lubrication free, always keeping your product and environment free from oil contamination.

Plain surface

The sandwich diaphragm has a completely plain surface, which eliminates bacteria growth problems. The diaphragm is available in food grade materials - PTFE or white EPDM.

Superior finish

Both liquid side and outside is electropolished*, to obtain superior finish and hygiene. Special surface finish may be done according to your requirements.

Variety of connection types

The pump is supplied as standard with SMS3017/ ISO2037 TC clamp connections. However, the pump may be equipped with almost any type of connection used in the hygienic field – DIN 11851 thread, SMS 1145 milk thread, DIN 11864 aseptic connections to mention a few.

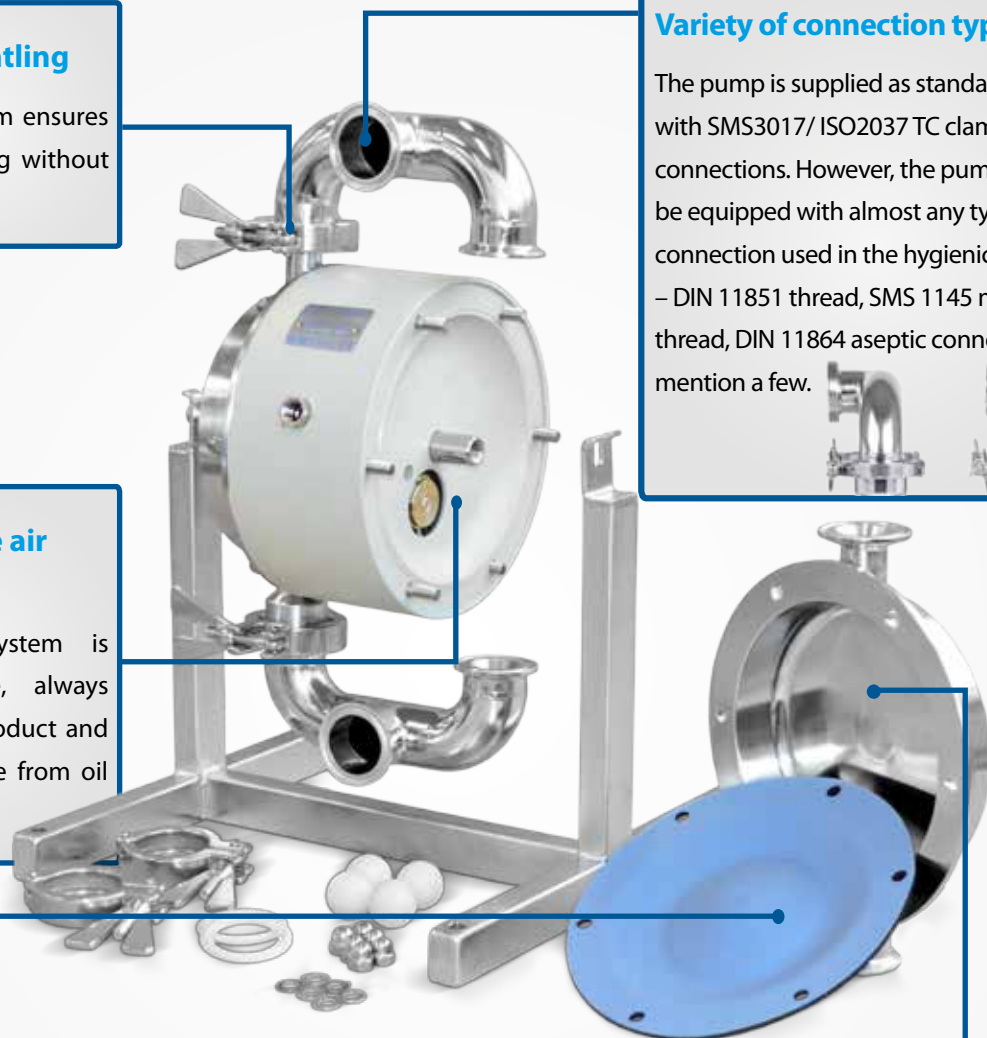

*T825 is glass blasted

■ Easy draining

Drain the pump by turning the pump in its support (T80-T825)

Our design allows for total visual inspection of the wetted parts. There are no hidden areas where bacteria can grow. The manifold clamps and the housing screws are simply removed for complete disassembly and cleaning. The pump is also designed for cleaning and sterilization in place – C.I.P. and S.I.P. After such operations, the pump is easily turned in its support for drainage.



Special versions



Heating jacket

The heating jacket is used when the pumped product has to maintain a specific temperature, high or low, throughout the process. A heating or cooling medium is continuously circulated in the heating jacket. The jacket is covering all the wetted parts of the pump.

» Available on all sanitary series pumps



Flap valves for big solids

Flap valves are available for the sanitary pumps, ideal in applications with bigger size and delicate solids.

The gentle pumping principle will maintain solids without any destruction.

Models available with flap valves:

- » T80 (18 mm solids max)
- » T125 (18 mm solids max)
- » T225 (44 mm solids max)
- » T425 (44 mm solids max)
- » T825 (100 mm solids max)

Magnetic ball lifters

Magnetic ball lifters are implemented in Sanitary AODD pumps, to enable pump emptying without removing it from the installation when no other draining option is available. Rotating the pump is no longer needed.



Counter-connections

In order to ease the pump connection with installation Tapflo has added a full range of counter-connections to sanitary pumps. They fit pumps with standard tri-clamp connection as well as optional DIN11851 and SMS connections.

Aseptic EHEDG series pumps

Keeping your process clean.



Tapflo Aseptic series pumps are designed for service in pharmaceutical-, biotech- and food industries where a clean process is the key.

Tapflo Aseptic series is EHEDG certified, has FDA and USP VI approved materials and conform to the ATEX directive 2014/34/EC.

Typical applications

Industry	Example of applications
» Food & dairy	Soup, cream, syrup, dairy products, flavoring, alcohol, chocolate, paste
» Pharmaceuticals & cosmetics	Cream, paste, alcohol and filtration gel



EN 10204



AT



■ Features & Benefits

- ✓ **No bacteria growth**
no horizontal areas
- ✓ **Easy cleaning and draining**
designed for CIP and SIP cleaning
- ✓ **Gentle pumping**
no damage of sensitive products
- ✓ **Wide range of connection types**
TriClamp, sanitary threads (DIN, SMS) etc.
- ✓ **Hygienic surfaces**
housings made from electro polished stainless steel AISI 316L, Ra < 0.8 (standard) or Ra < 0.5 (on request)
- ✓ **No leakage**
no rotating shaft seals
- ✓ **Flexible installation**
self-priming
- ✓ **Reliable in service**
can run dry and against closed valve without damage
- ✓ **Environmental friendly**
lube free air valve
- ✓ **Hygienic diaphragms**
designed without any nuts or plates on the pumped side

The EHEDG certificate

The EHEDG (European Hygienic Engineering & Design Group) certificate is your guarantee that the design is according to the hygienic guidelines. Furthermore the pump is clean ability tested, which means bacteria does not grow in the pump after cleaning and draining procedure.



Keeping your process clean

Smooth surfaces and clean ability are important keys for the EHEDG certification

Technical data

Data			
Model	TX94	TX144	TX244
Max flow	94 l/min	144 l/min	330 l/min
Max pressure	8 bar	8 bar	8 bar
Max air pressure	8 bar	8 bar	8 bar
Dry suction lift	2 m	3 m	4.4 m
Max solid size	6 mm, bigger if soft	6 mm, bigger if soft	10 mm, bigger if soft
Temperature	-20° +110°C (temporary higher)		
Weight	15 kg	22 kg	46 kg
Connections	Triclamp (standard), SMS, DIN and RJT threads, DIN 11864 clamp		
ATEX details	Group II, cat 2, T4		
Materials and options			
Housing, manifolds	AISI 316L, Ra < 0.8 Ra < 0.5 on request		
Diaphragms	PTFE (FDA & USP VI) PTFE 1705B (solvents, FDA & USP VI) EPDM (FDA on request) White EPDM (FDA) PTFE with white back (FDA & USP VI)		
Valves (ball type)	PTFE (FDA) PTFE (USP VI & FDA) EPDM (FDA on request) AISI 316L		
O-rings	EPDM (FDA) EPDM (USP VI & FDA) FEP/FKM (FDA)		
Options	Backup diaphragm system		

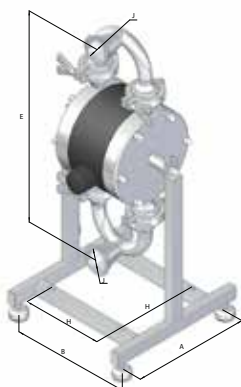

Changes reserved without notice

Performance curves

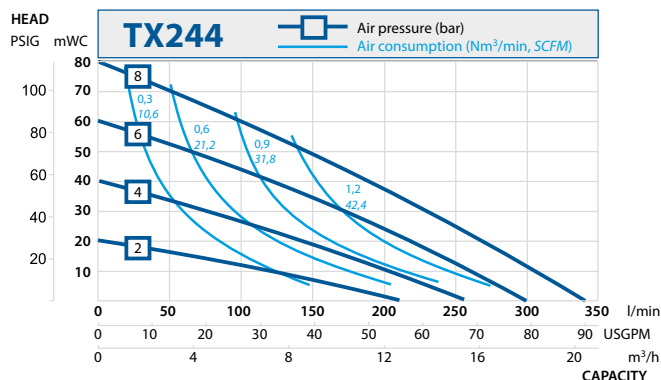
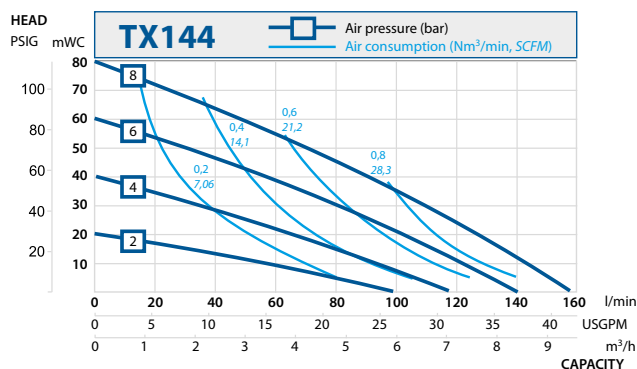
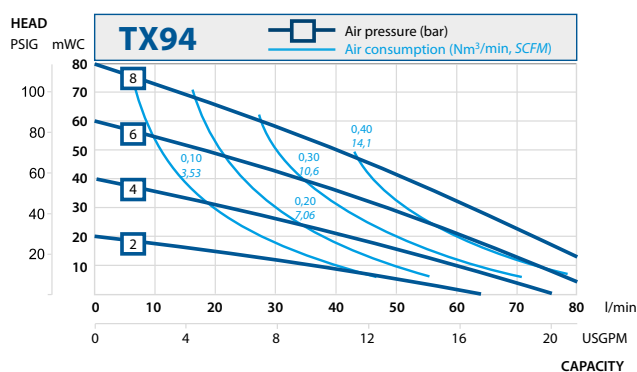

Dim	Pump size		
	TX94	TX144	TX244
A	260	280	360
B	275	278	340
E	447	488	700
H	185	188	270
J	DN 40	DN 50	DN 65

Dimensions in mm (where other is not indicated)

Intelligent pumps - TC series



TC Intelligent pumps are fitted with ingenious LEAP® technology developed by Tapflo.

LEAP® or 'Low Energy Air Pump' is a patented technology used in AODD pumps to reduce the minimum operating air pressure by reducing internal losses and friction found in conventional AODD pumps.

LEAP uses a unique indirect system to detect the position of the diaphragm shaft controlling the diaphragm movement automatically.

■ Features & Benefits

- ✓ Available in Plastic, Metal and Sanitary series AODD pumps
TC50 - TC425 (T50 - T425 equivalent)

✓ Retrofit
Leap can be fitted to any existing Tapflo Air Operated Diaphragm Pumps

✓ Batch Dispensing
allowing the pump to automatically stop after the required volume has been dispensed.

✓ Improved Lifespan
the TC series uses an air valve that has a significantly longer life expectancy over rubber seal technology.

✓ Dry Running
by analysing the frequency of pulses, the pump can analyse when it is running dry.
- ✓ Noise Reduction
ability to utilise lower air pressure reduces the noise of the pump

✓ Electrical feedback
signal allows for external monitoring of the pump process.

✓ Improved Maintenance
main air valve can be changed in under two minutes without the removal of the pump from the process line.

✓ Control Simplification
no need for an external pneumatic solenoid valve, reducing costs and simplifying control.

✓ Dead Heading
as with dry running, the frequency of pulses can be monitored, alerting if the pump has a blockage.

Graph showing fluid flow against air pressure required

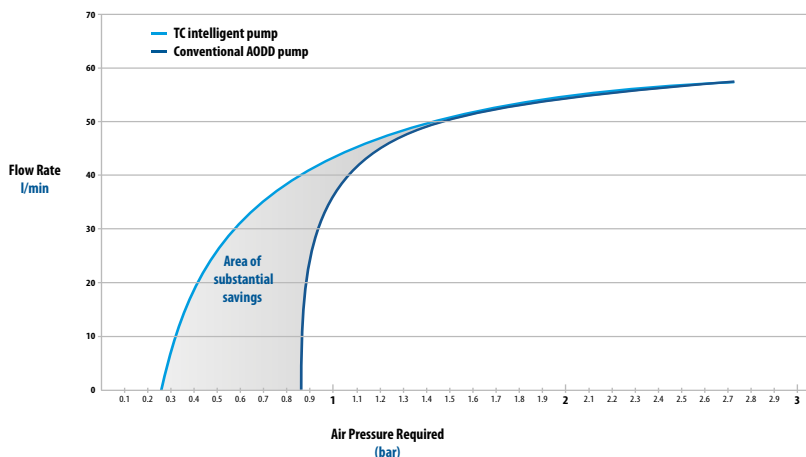

The pump fitted with LEAP® Technology is able to **start pumping at 0.3 bar without stalling**, in test the pump was already achieving flow rates of **70% of its maximum open end flow before other pumps had even started.**

Filter press pumps - TF series

The Tapflo pump station for filter press feeding is a very compact unit that can be mounted directly to the filter press.



TF series

The design and function allows the user a straightforward pressing of slurries. Pressure regulator is already mounted to the unit.

An external pressure booster doubles the delivery pressure. For example, with available air pressure of 7 bar, the delivery pressure will be maximum 14 bar.

The pump stations are based on the standard Tapflo pumps:

PE & FTFE: TF 50 | TF 100 | TF 200 | TF 400

Metal pumps: TF 70 | TF 120 | TF 220 | TF 420

Features & Benefits

- ✓ Can run dry
- ✓ Self priming
- ✓ High pressure transmission up to 1:2
- ✓ Few parts – easy to maintain
- ✓ Long service life
- ✓ Reliable and compact

The Installation

Adding a pump to an existing filter press was never such easy. **Just mount it on the filter press and connect it.** The pump is already equipped with a pressure booster, manometers, regulation knob and all essential hoses and fittings.

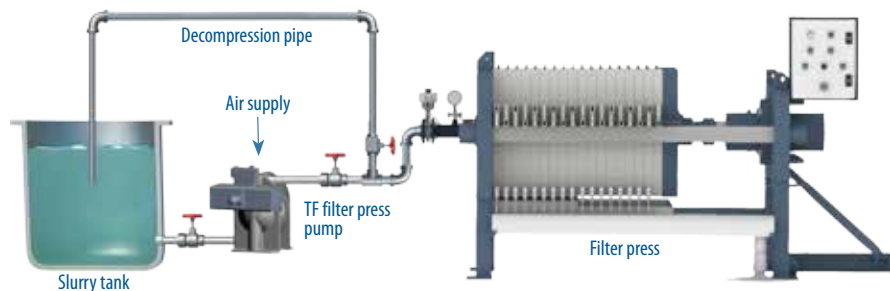

Technical data

Pump size	Connection size (" BSP or NPT)	*Max capacity (l/min) / (US GPM)	Max pump pressure (bar) / (PSI)
TF 50 TF 70	1/2" 3/4"	*60 / 15.8	16 / 232
TF 100 TF 120	1"	*125 / 33	16 / 232
TF 200 TF 220	1 1/2"	*330 / 87	12 / 174
TF 400 TF 420	2"	*570 / 150	12 / 174

* = This max flow is obtained when using a bypass round the pressure booster at low pressure

Powder pumps - TP series



Reduced contamination

The powder is transferred in a hermetic system from the powder container to your process.

Economical and compact solution

The Tapflo powder transfer pump can do the same job as many complex and large powder systems. The compact design also makes the unit portable.

What kind of powders?

The powder transfer pump will handle different types of process powders, with specific weight from 80 up to 720 kg/m³ dry weight. Generally, if the powder does not clump together when squeezed in hand, the Tapflo powder transfer pump can be used successfully. A few examples of common powders are *sintering powder, carbon black, resins and silicones*.

Capacity

The capacity of the powder transfer is extremely different from one powder to another, depending on the consistency and weight etc.



Working principle

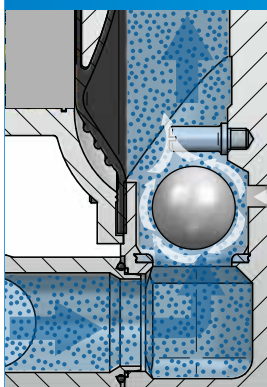

No start up problems

The air induction system eliminates powder pack up problems when starting the pump.

Air is induced to the powder side of the pump for diffusion of the powder. The induction flow can manually be adjusted by means of a needle valve to obtain a optimum performance.

Features & Benefits

- Economical**
compared with other complex powder systems
- Convenient**
and safer than manual powder handling

Technical data

Model	TXP120	TXP220	TXP420
In/outlet connections	1" BSP threads (NPT upon request)	1 1/2" BSP threads (NPT upon request)	2" BSP threads (NPT upon request)
Features	Complete air induction system included		
Explosion protection	ATEX marked according to group IIG (gas) / IID (dust), category 2		
Housing material	PTFE coated aluminium		
Diaphragm material	EPDM (NBR or PTFE upon request)		
Valve material	EPDM (NBR, PTFE, AISI 316 or PU upon request)		
In/outlet material	Stainless steel AISI 316L		

Pharmaceutical pumps - TU series

USP VI approved pharmaceutical series pumps air driven pump for pharmaceutical and biotech industries



This pump series was developed in co-operation with one of the world leading supplier to the biotech market. It serves the biotech- and pharmaceutical industries in numerous applications.

Our unique USP approved (United States Pharmacopoeia) hygienic PE pump, features all wetted parts in USP class VI certified materials.

Simplicity

Pump housing with only three parts makes it extremely easy to maintain.

Superior finish

High finish and hygienic approved materials.



EN 10204



The Pharmaceutical series pumps

>> TU53 PTT-5UVI	60 l/min; ¾"
>> TU103 PTT-5UVI	125 l/min; 1"
>> THU203 PTT-5UVI	330 l/min; 1 ½"
>> THU403 PTT-5UVI	570 l/min; 2"

■ Features & Benefits

✓ Sanitary design
smooth internal surfaces

✓ USP class VI
approved materials

✓ Inert materials
no contamination of the
pumped product

✓ Extremely easy to maintain
pump housing with very few
components

Active pulsation dampeners

The Tapflo pulsation dampener works actively with compressed air and a diaphragm, automatically setting the correct pressure to minimise the pulsations.



The active pulsation dampener is the most efficient way to remove pressure variations on the discharge of the pump.

The Tapflo pulsation dampener works actively with compressed air and a diaphragm, automatically setting the correct pressure to minimise the pulsations.

Explosion proof models are available
 Certified according to directive 2014/34/EC (ATEX), group II, cat 2, for use in EX-zone 1. **Contact us for information.**



EN 10204



Working principle

When the pressure in the piping system decreases, due to the pulsating nature of the pump operation, the pulsation dampener supplies extra pressure to the discharge between the pump strokes, therefore supplying a steady flow of pumped medium. This pumping action created by the dampener, decreases the pressure variations and pulsations.

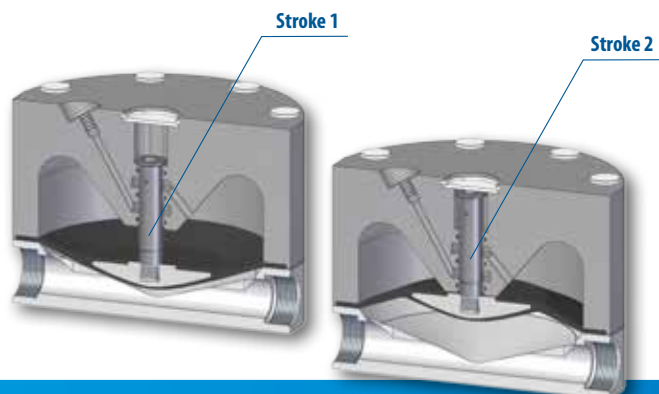

■ The dampening effect

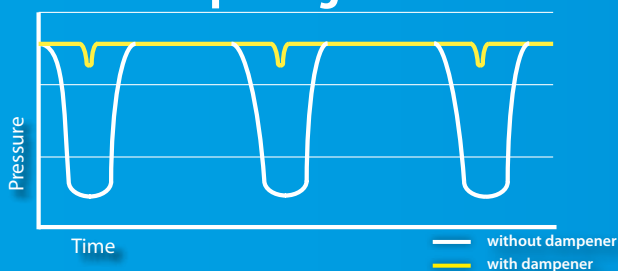

The dampening effect

The pressure variation in a discharge line with and without a pulsation dampener.

- Minimized vibrations and water hammer effects
- Protection of all kinds of instruments in your piping system
- Optimized pump performance and reduced maintenance costs

Options & accessories



■ Pulsation dampener with stand



■ Pulsation dampener with pump



■ Pulsation dampener with guardian



■ TK built-on dampener

Systems & accessories

Guardian systems



The Guardian is an energy conservation device designed to protect an air operated double diaphragm (AODD) pump from operating in an inefficient manner that uses unnecessary energy and reduces the life of its parts. It also offers the added benefit of providing greater safety to applications of high risk.

The Guardian directly monitors the discharge fluid pressure against its set point stopping the pump if the media pressure increases above the set point (closed valve) or falls below the set point (dry-run) dependant on configuration.

Applications of Guardian systems

Barrier Protection

Barrier pumps (TB) have an additional set of diaphragms used to back-up the primary diaphragms. In case of a breach the liquid remains inside the pump, instead of leaking out through the air exhaust. The Guardian monitors the pressure between the primary and secondary diaphragms, stopping the pump if the pressure increases above the set point.

Dry run & stop

The Guardian monitors the fluid discharge pressure of the pump, stopping it if the pressure falls below the set point, caused by a lack of media on the suction causing air to be ingested into the pump.

Dead head & stop

The Guardian monitors the fluid discharge pressure of the pump, stopping it if the pressure rises to the set point, caused by a closed valve or over pressure in the discharge line.

Dead head & restart

The Guardian monitors the fluid discharge pressure of the pump, stopping it if the pressure rises to the set point, caused by a closed valve or over pressure in the discharge line. When the pressure falls below the set pressure, the pump automatically restarts.



Control systems

Pneumatic level control



This ingenious system is operated with pneumatic components only to start (automatic with TPUK-LA or manual with TPUK-LM) and automatic stop the pump at certain liquid levels. The level control may be installed in sumps, tanks or tubs.

Pneumatic batch control



Pneumatic batcher can control any Tapflo AODD pump to produce accurate and repeatable dispensed volumes. Fully programmable allowing you to set the batch amount (TPUK-BP) or batch time (TPUK-BT).

Stroke counter - low pressure VFC



A stroke to volt free contact (VFC) is available for integration with PLC systems. Simply connect to any AODD pump via the air exhaust muffler to monitor the pump strokes.

Life counter TPUK-LC



Tapflo's life counter simply connects to the AODD pump air exhaust, representing the strokes on the LCD display. Compact, easy to use and cost effective this simple system will allow you to control servicing and implement a preventative maintenance routine.

Mobile solutions for pump units and systems

Mobile pump units are found as the best solution for the users of spread technological processes. The portability of the Units allows easy movement to various locations. This means almost limitless application.

Trolley S | 2-wheel

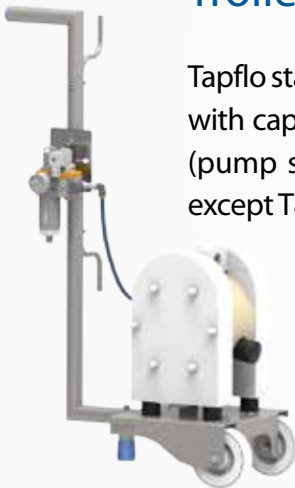

Tapflo standard AODD pumps with capacity up to 125 l/min (pump sizes: up to 100/120, except T80),

Trolley M | 4-wheel



Tapflo standard AODD pumps with capacity up to 570 l/min (pump sizes: up to 400/420, except T425),

For further details, please check the separate brochure systems & accessories for pumps

Filter regulator & needle valve kit

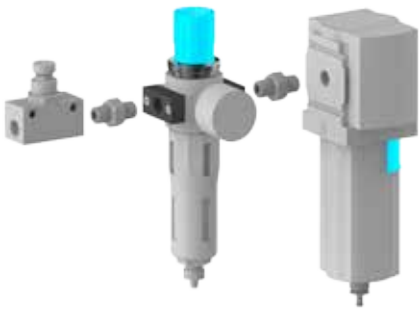

There are many benefits of using an individual filter regulator and needle valve for your AODD pump. You will always be able to run the pump with right air quality and optimum pressure and speed to save energy. Furthermore the lifetime of pump components will increase. The kit includes a filter regulator, gauge, wall bracket, needle valve, and/ or water separator. The filter is 5 micron and regulator is 0-12 bar, available in sizes 1/8" up to 3/4".

Pneumixer



The Pneumixer was predominantly developed for the paint and ink industry where most raw materials in drums or containers settle out over time and need to be mixed or blended prior to use. This usually means rolling, shaking or pumping to a mixing vessel; that adds time, waste, mess and expense.

■ Features & Benefits

- ✓ No paddles
- ✓ No rotating blades
- ✓ Variable agitation
- ✓ Suits all containers up to 1000 litre IBC
- ✓ No moving parts utilises pump power to mix & dispense
- ✓ Eliminates problems with conventional mixing
- ✓ No air entrainment
- ✓ No shear
- ✓ Closed vessel mixing system
- ✓ Fully controllable pneumatic operation and control
- ✓ Reduced environmental exposure
- ✓ No need for pumping to mixing vessel

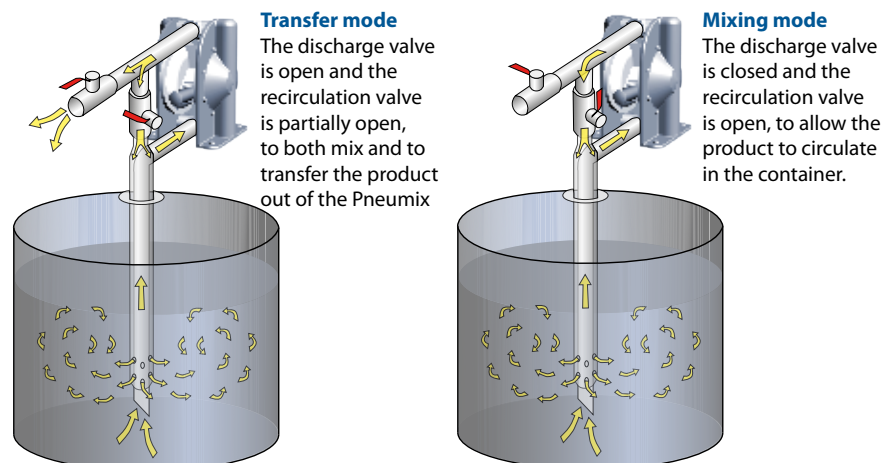

TAPFLO AB

Sweden

Filaregatan 4 | S-442 34 Kungälv

Tel: +46 303 63390

Fax: +46 303 19916

E-mail addresses:

Commercial questions: sales@tapflo.com

Orders: order@tapflo.com

Tech support: support@tapflo.com

Tapflo products and services are available in 75 countries on 6 continents.

Tapflo is represented worldwide by own Tapflo Group Companies and carefully selected distributors assuring highest Tapflo service quality for our customers' convenience.

AUSTRALIA | AUSTRIA | AZERBAIJAN | BAHRAIN | BELARUS | BELGIUM | BOSNIA | BRAZIL | BULGARIA | CANADA | CHILE | CHINA | COLOMBIA | CROATIA | CZECH REPUBLIC | DENMARK | ECUADOR | EGYPT | ESTONIA | FINLAND | FRANCE | GREECE | GEORGIA | GERMANY | HONG-KONG | HUNGARY | ICELAND | INDIA | INDONESIA | IRAN | IRELAND | ISRAEL | ITALY | JAPAN | JORDAN | KAZAKHSTAN | KUWAIT | LATVIA | LIBYA | LITHUANIA | MACEDONIA | MALAYSIA | MEXICO | MONTENEGRO | MOROCCO | THE NETHERLANDS | NEW ZEALAND | NORWAY | POLAND | PORTUGAL | PHILIPPINES | QATAR | ROMANIA | RUSSIA | SAUDI ARABIA | SERBIA | SINGAPORE | SLOVAKIA | SLOVENIA | SOUTH AFRICA | SOUTH KOREA | SPAIN | SUDAN | SWEDEN | SWITZERLAND | SYRIA | TAIWAN | THAILAND | TURKEY | UKRAINE | UNITED ARAB EMIRATES | UNITED KINGDOM | USA | UZBEKISTAN | VIETNAM

Tapflo Group Companies

Austria

Tapflo Austria
Tel: +43 732 27292910
sales@tapflo.at

Azerbaijan

Tapflo Azerbaijan LLC
Tel: +994 502660799
sales@tapflo.az

Baltic States

Tapflo Latvia
Tel: +371 67472205
sales@tapflo.lv

Belarus

Tapflo Belarus
Tel: +375 17 3934609
sales@tapflo.by

Bulgaria

Tapflo EOOD
Tel: +359 (0)2 974 18 54
office@tapflo.bg

Canada

Tapflo Canada
Tel: +1 514 813 5754
canada@tapflo.com

Croatia

Tapflo GmbH
Tel: +385 91 4884 666
sales@tapflo.hr

Czech Republic

Tapflo s.r.o.
Tel: +420 513 033 924
tapflo@tapflo.cz

China

Tapflo (Wuxi)
Tel: +86 510 8241 7602
sales@tapflo.cn

Denmark

Tapflo Danmark
Tel: +45 36 454600
info@tapflo.dk

France

Tapflo France
Tel: +33 1 34 78 82 40
info@tapflo.fr

Georgia

Tapflo Georgia
Tel: +995 577 463010
sales@tapflo.ge

India

Tapflo Fluid Handling India Pvt Ltd
Tel: +91 20 65000215
ac@tapflo.in

Ireland

Tapflo Ireland Ltd
Tel: +353 1 2011911
info@tapflo.ie

Italy

Tapflo Italia
Tel: +39 0362307698
info@tapfloitalia.com

Japan

Tapflo Japan K.K.
Tel: +81-3-6240-3510
tapflojp@tapflo.co.jp

Kazakhstan

Tapflo Kazakhstan
Tel: +7 727 3278347
sales@tapflo.kz

Poland

Tapflo Sp. z o.o.
Tel: +48 58 530 42 12
info@tapflo.pl

Romania

S.C. Tapflo Rom. S.r.l.
Tel: +40 21 3451255
sales@tapflo.ro

Russia

Tapflo Company
Tel: +7 495 232 18 28
sales@tapflo.com.ru

Serbia

Tapflo d.o.o.
Tel: +381 21 44 58 08
sales@tapflo.rs

Slovakia

Tapflo s.r.o.
+421 911 137 883
tapflo@tapflo.sk

Slovenia

Tapflo GmbH
Tel: +386 68 613 474
sales@tapflo.hr

Spain

Tapflo Iberica
Tel: +34 91 8093182
avives@tapfloiberica.es

South Africa

Tapflo (Pty) Ltd
Tel: +27 31 701 5255
sales@tapflo.co.za

Turkey

Tapflo Makina Ltd
Tel: +90 216 467 33 11
sales@tapflo.com.tr

Ukraine

TOB Tapflo
Tel: +380 44 222 68 44
sales@tapflo.com.ua

Uzbekistan

Tapflo Uzbekistan
Tel: +998 712370940
sales@tapflo.uz

United Kingdom

Tapflo (UK) Ltd
Tel: +44 2380 252325
sales@tapflo pumps.co.uk

www.tapflo.com